

--

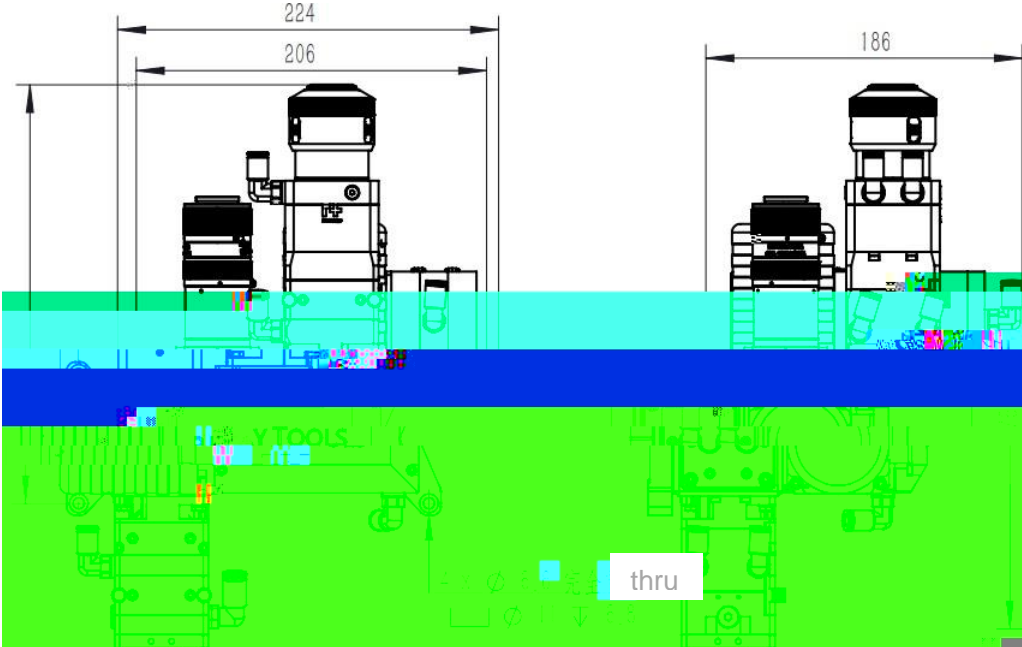

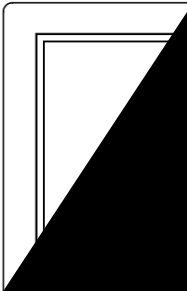

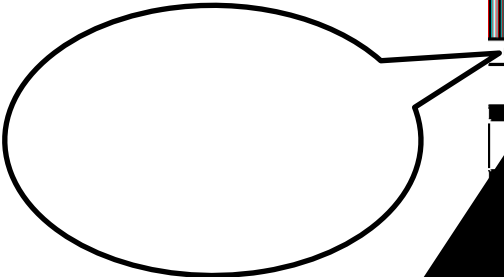





Rear View

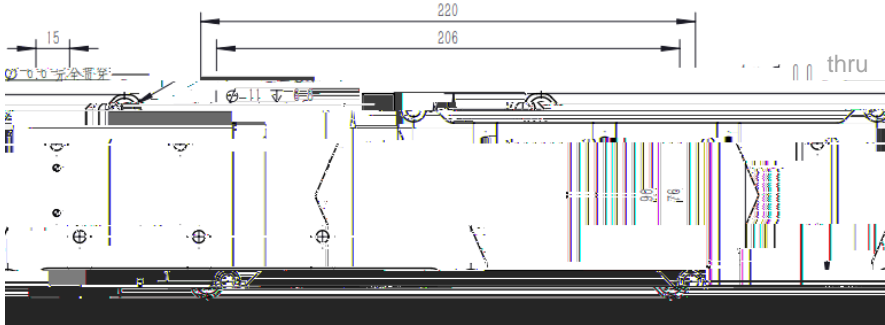

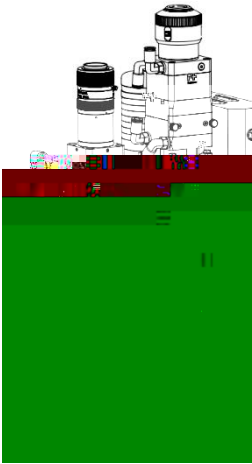
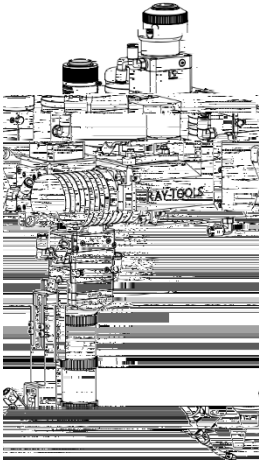
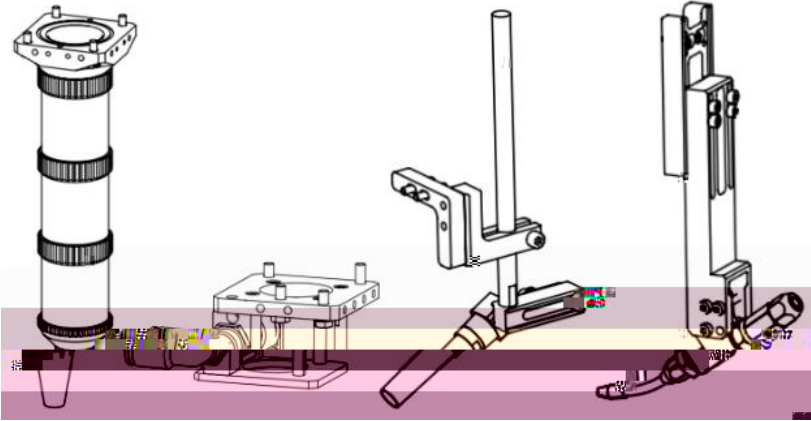





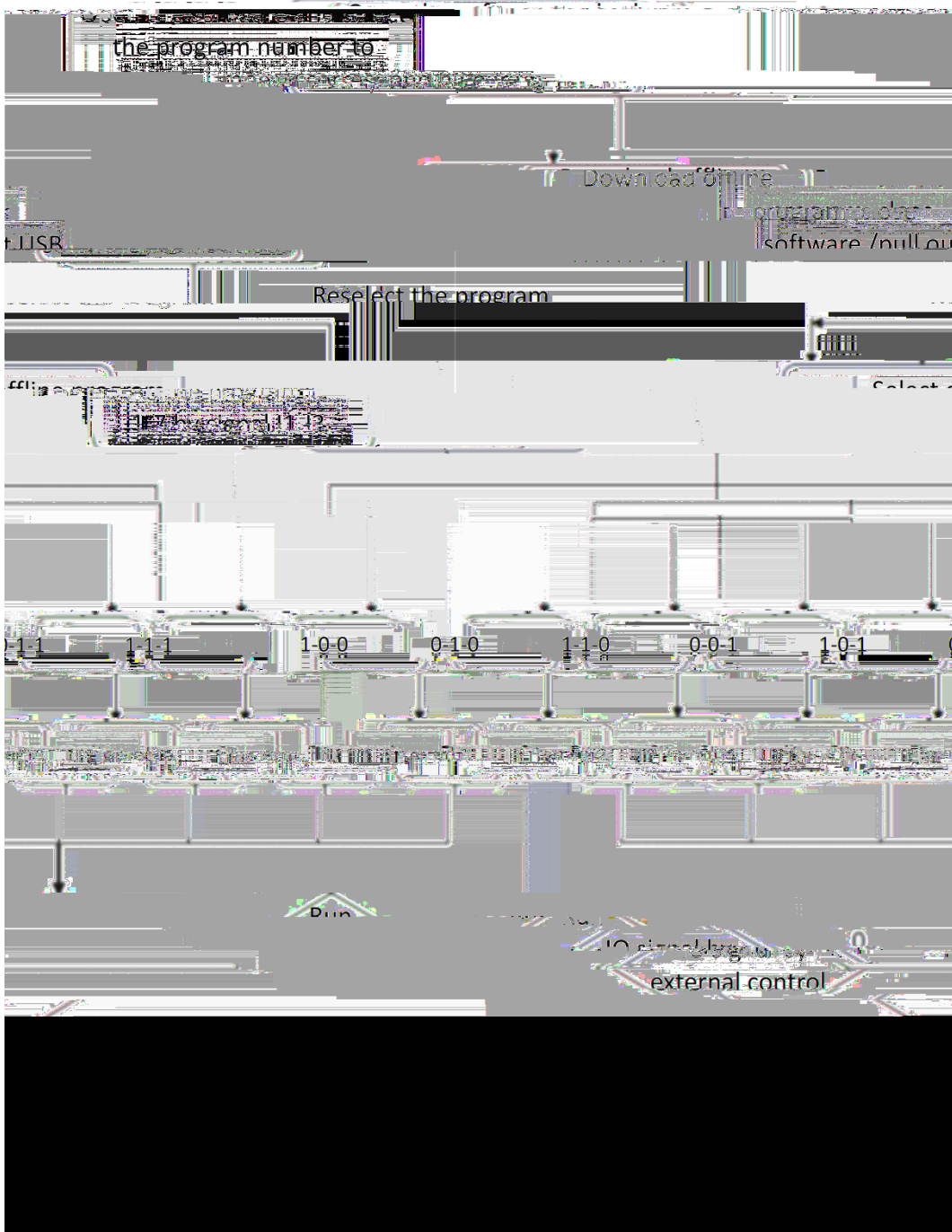

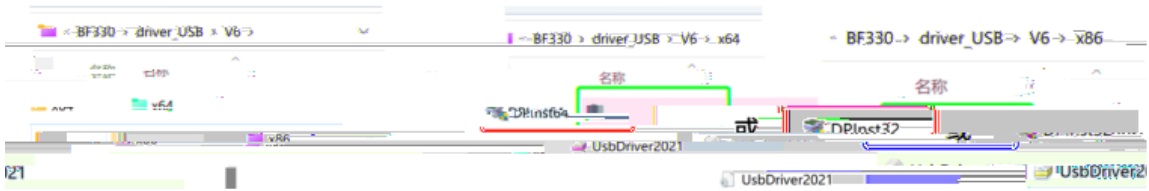

	2021/4/6 15:47	XML 文档	1 KB
	2021/3/23 14:31	应用程序	1 KB
	2021/3/23 14:31	应用程序	10.460 KB
	2021/3/23 14:31	应用程序	1.536 KB
	2021/4/6 16:50	应用程序	576 KB
j	2021/3/23 14:31	CONFIG 文件	1 K
	2021/4/6 16:50	PDB 文件	228 K

μ

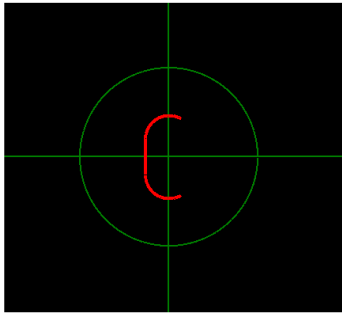

Graphics Settings

ProgramID

WeldType

Line Length mm

Radius mm

StartAngle

Spin angle

Frequency

X Offset mm

Y Offset mm

[Download](#)

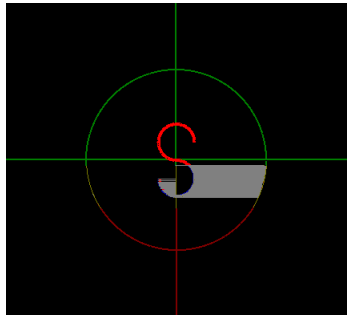

Graphics Settings

ProgramID

WeldType

Line Length mm

Radius mm

StartAngle

Spin angle

Frequency

X Offset mm

Y Offset mm

[Download](#)

